

# Anomalous transport: Theory and Applications - I

Karl Landsteiner

Instituto de Física Teórica UAM-CSIC



Holography and Topology of Quantum Matter, APCTP, Pohang 2016

# Outline

- Anomalous Triangles
- Weyl vs. Dirac
- Covariant vs. Consistent Anomalies
- Landau Levels and spectral flow
- Landau Levels and Transport

# Anomalous Triangles

## Weyl equation:

When the restmass  $m=0$  Weyl realized that the Dirac equations decomposes into two independent simpler equations

$$(i\vec{\sigma}\vec{p})\Psi_L = E\Psi_L$$

$$(-i\vec{\sigma}\vec{p})\Psi_R = E\Psi_R$$

- $\sigma_i$  are 2x2 Pauli matrices
- $\Psi_{L,R}$  are a 2 component spinors
- symmetries:  $\Psi_{L,R} \rightarrow e^{i\alpha_{L,R}} \Psi_{L,R}$
- $n_{L,R}$  separately conserved
- Spin and momentum either aligned or anti-aligned: CHIRAL
- $E=|p|$

# Anomalous Triangles

## Weyl equation:

When the restmass  $m=0$  Weyl realized that the Dirac equations decomposes into two independent simpler equations

$$(i\vec{\sigma}\vec{p})\Psi_L = E\Psi_L$$

$$(-i\vec{\sigma}\vec{p})\Psi_R = E\Psi_R$$

- $\sigma_i$  are 2x2 Pauli matrices
- $\Psi_{L,R}$  are a 2 component spinors
- **symmetries:**  $\Psi_{L,R} \rightarrow e^{i\alpha_{L,R}} \Psi_{L,R}$
- $n_{L,R}$  separately conserved
- Spin and momentum either aligned or anti-aligned: **CHIRAL**
- $E=|p|$

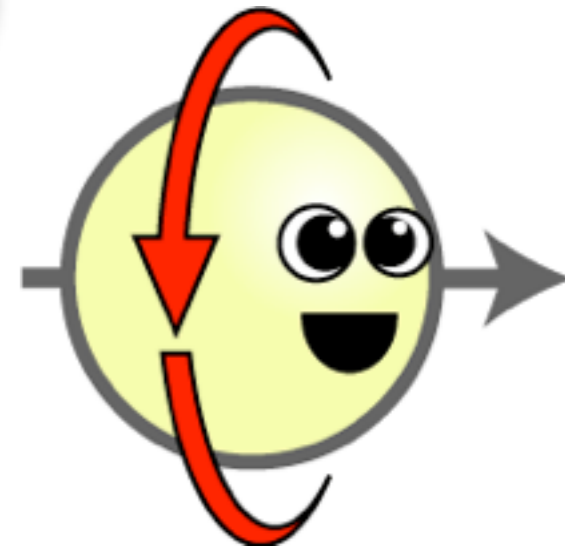

# Anomalous Triangles

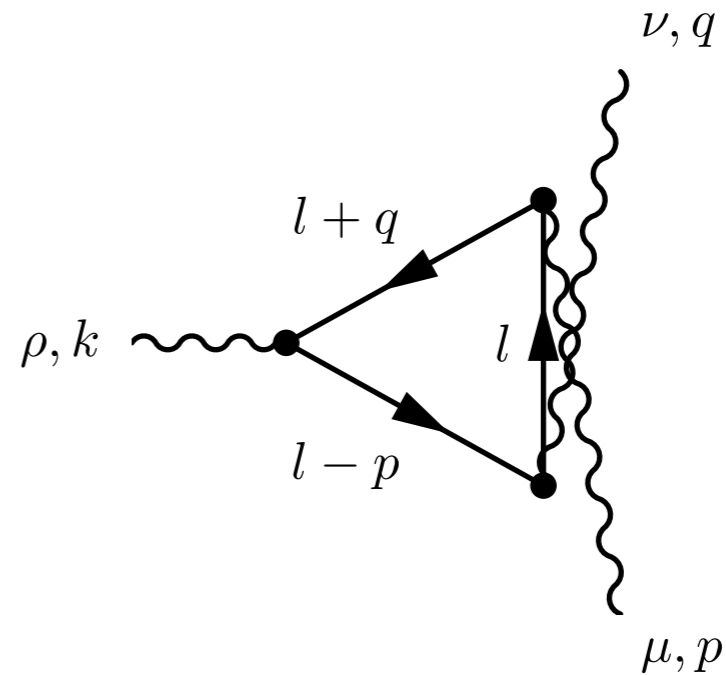
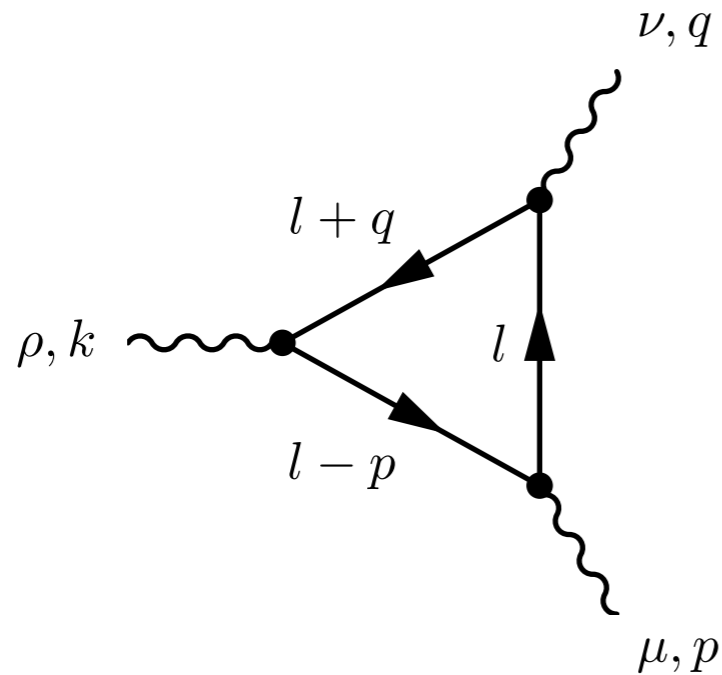

$$\langle J_L^\rho(k) J_L^\mu(p) J_L^\nu(q) \rangle = i \int \frac{d^4 l}{(2\pi)^4} \frac{N^{\mu\nu\rho}}{(l-p)^2 l^2 (l+q)^2}$$

naively symmetry implies:

$$k_\rho \langle J_L^\rho(k) J_L^\mu(p) J_L^\nu(q) \rangle = p_\mu \langle J_L^\rho(k) J_L^\mu(p) J_L^\nu(q) \rangle = q_\nu \langle J_L^\rho(k) J_L^\mu(p) J_L^\nu(q) \rangle = 0$$

# Anomalous Triangles

$$\text{tr}[\gamma^\alpha \gamma^\mu \gamma^\beta \gamma^\nu \gamma_5] = 4i\epsilon^{\alpha\mu\beta\nu}$$

$$k_\rho A^{\rho\mu\nu}(k, p, q) = \epsilon^{\alpha\nu\beta\mu} \int \frac{d^4 l}{(2\pi)^2} \left( \frac{l_\alpha(l-p)_\beta}{(l-p)^2 l^2} - \frac{l_\alpha(l+q)_\beta}{(l+q)^2 l^2} \right) + (\mu \leftrightarrow \nu) = \mathbf{0}$$

$$p_\alpha p_\beta$$

$$q_\alpha q_\beta$$

$$l \rightarrow l - q$$

So far so good, but:

$$p_\rho A^{\rho\mu\nu}(k, p, q) = \epsilon^{\alpha\nu\beta\mu} \int \frac{d^4 l}{(2\pi)^2} \left( \frac{l_\alpha q_\beta}{(l-p)^2 l^2} - \frac{(l-p)_\alpha (p+q)_\beta}{(l-p)^2 (l+q)^2} \right) + (\mu \leftrightarrow \nu)$$

**Crux:** linearly divergent integral

$$\int_{-\infty}^{\infty} dx f(x+a) = \int_{-\infty}^{\infty} f(x) + a f'(x) \Big|_{x=-\infty}^{x=+\infty}$$

# Anomalous Triangles

$$\text{tr}[\gamma^\alpha \gamma^\mu \gamma^\beta \gamma^\nu \gamma_5] = 4i\epsilon^{\alpha\mu\beta\nu}$$

$$k_\rho A^{\rho\mu\nu}(k, p, q) = \epsilon^{\alpha\nu\beta\mu} \int \frac{d^4 l}{(2\pi)^2} \left( \frac{l_\alpha(l-p)_\beta}{(l-p)^2 l^2} - \frac{l_\alpha(l+q)_\beta}{(l+q)^2 l^2} \right) + (\mu \leftrightarrow \nu) = 0$$

So far so good, but:

$$p_\rho A^{\rho\mu\nu}(k, p, q) = \epsilon^{\alpha\nu\beta\mu} \int \frac{d^4 l}{(2\pi)^2} \left( \frac{l_\alpha q_\beta}{(l-p)^2 l^2} - \frac{(l-p)_\alpha (p+q)_\beta}{(l-p)^2 (l+q)^2} \right) + (\mu \leftrightarrow \nu)$$

$p_\alpha p_\beta$

$q_\alpha q_\beta$

~~$l \rightarrow l - q$~~

**Crux: linearly divergent integral**

$$\int_{-\infty}^{\infty} dx f(x+a) = \int_{-\infty}^{\infty} f(x) + a f'(x) \Big|_{x=-\infty}^{x=+\infty}$$

# Anomalous Triangles

- Diagram is sensitive to momentum routing
- Most general routing

$$l^\mu \rightarrow l^\mu + c(p - q)^\mu + d(p + q)^\mu$$

$$p_\mu A^{\rho\mu\nu} = \frac{-i}{8\pi^2} (1 - c) \epsilon^{\rho\nu\alpha\beta} q_\alpha p_\beta$$

$$q_\nu A^{\rho\mu\nu} = \frac{-i}{8\pi^2} (1 - c) \epsilon^{\rho\mu\alpha\beta} q_\alpha p_\beta$$

$$q_\nu A^{\rho\mu\nu} = \frac{-i}{8\pi^2} 2c \epsilon^{\rho\mu\alpha\beta} p_\alpha q_\beta$$

“When radiative corrections are finite but undetermined”

[Jackiw, hep-th/9903044]

- What is the the “right” value for  $c$  ?



# Anomalous Triangles

- Beyond Math: Physics constraints
- Single Weyl fermion

$$J^\mu = \frac{\delta\Gamma}{\delta A_\mu}$$

$$A^{\rho\mu\nu} = \frac{\delta^3\Gamma}{\delta A_\rho \delta A_\mu \delta A_\nu}$$

- Fixes  $c=1/3$
- Coupling to external fields

$$\partial_\mu J_{L,R}^\mu = \pm \frac{1}{96\pi^2} \epsilon^{\mu\nu\rho\lambda} F_{\mu\nu} F_{\rho\lambda}$$

“consistent anomaly”

# Anomalous Triangles

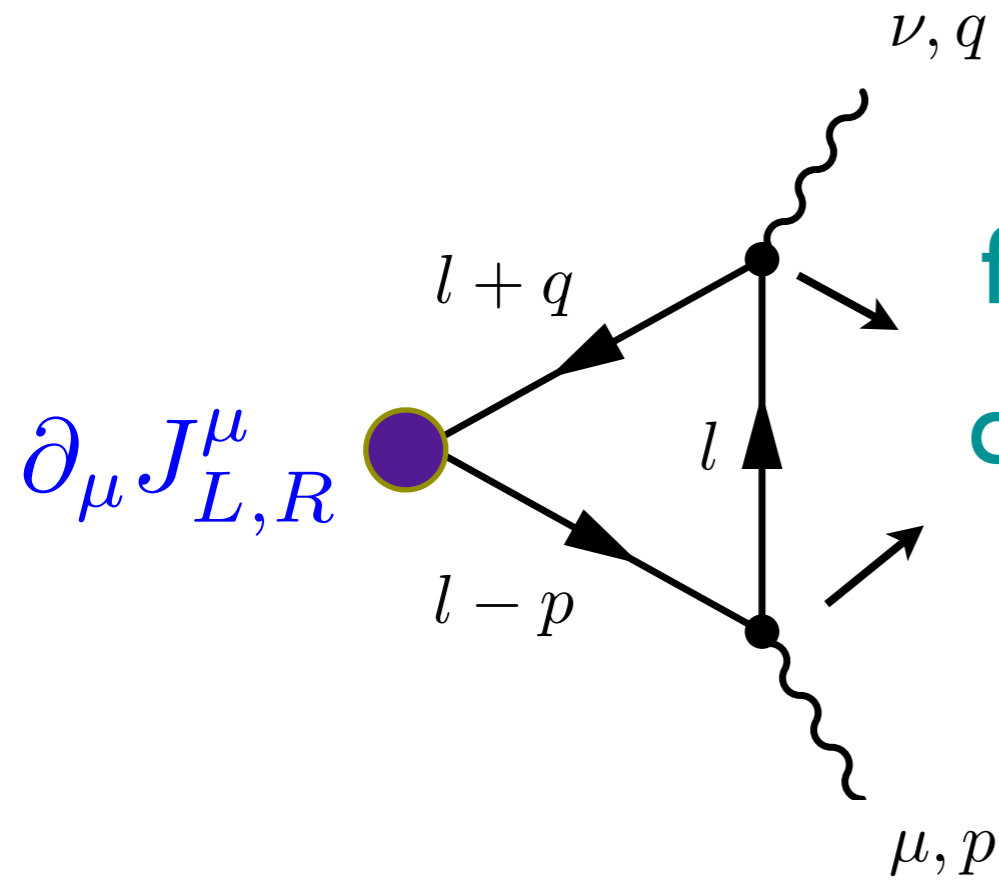

free of anomaly,  $c=1$

current couples **covariantly** to external fields

$$\partial_\mu J_{L,R}^\mu = \pm \frac{1}{32\pi^2} \epsilon^{\mu\nu\rho\lambda} F_{\mu\nu} F_{\rho\lambda}$$

“covariant anomaly”

Bose symmetry is broken:  $J_{\text{cov}}^\mu \neq \frac{\delta\Gamma}{\delta A_\mu}$

# Dirac Anomaly

$$\Psi_D = \Psi_L \oplus \Psi_R \quad (\text{classically})$$

Just add and subtract currents:

$$J^\mu = J_L^\mu + J_R^\mu$$

$$J_5^\mu = J_L^\mu - J_R^\mu$$

$$A^\mu = \frac{1}{2}(A_L^\mu + A_R^\mu)$$

$$A_5^\mu = \frac{1}{2}(A_L^\mu - A_R^\mu)$$

Trouble ahead:

$$\partial_\mu J^\mu = 4C \epsilon^{\mu\nu\rho\lambda} F_{\mu\nu} F_{\rho\lambda}^5$$

$$C_{\text{cov}} = \frac{1}{32\pi^2}$$

$$\partial_\mu J_5^\mu = 2C \epsilon^{\mu\nu\rho\lambda} (F_{\mu\nu} F_{\rho\lambda} + F_{\mu\nu}^5 F_{\rho\lambda}^5)$$

$$C_{\text{cons}} = \frac{1}{96\pi^2}$$

Non of the resulting currents is really conserved

$$\langle \partial_\mu J^\mu O_1 \cdots O_n \rangle = 0$$

# Dirac Anomaly

Cure exists for consistent current: **Bardeen counterterms**

$$\Delta\Gamma = \int d^4x \epsilon^{\mu\nu\rho\lambda} A_\mu A_\nu^5 (c_1 F_{\rho\lambda} + c_2 F_{\rho\lambda}^5)$$

$$J^\mu = \frac{\delta(\Gamma + \Delta\Gamma)}{\delta A_\mu} \quad J_5^\mu = \frac{\delta(\Gamma + \Delta\Gamma)}{\delta A_\mu^5}$$

starting from L,R symmetric treatment and  
choosing now  $c_1 = -\frac{1}{12\pi^2}$  ,  $c_2 = 0$

$$\partial_\mu J^\mu = 0$$

$$\partial_\mu J_5^\mu = \epsilon^{\mu\nu\rho\lambda} \left( \frac{1}{16\pi^2} F_{\mu\nu} F_{\rho\lambda} + \frac{1}{48\pi^2} F_{\mu\nu}^5 F_{\rho\lambda}^5 \right)$$

# WZ Consistency Condition

Anomaly:  $\delta_\lambda \Gamma = \mathcal{A}_\lambda$

$\swarrow$   $\searrow$

non-local      local

$$[\delta_\lambda, \delta_\sigma] \Gamma = \delta_\lambda \mathcal{A}_\sigma - \delta_\sigma \mathcal{A}_\lambda = 0$$

BRST formalism: Grassmann valued gauge parameter “ghost”

$$\lambda \rightarrow c, \quad \delta_c \rightarrow s, \quad s^2 = 0$$

Cohomology problem

$$sA = 0, \quad A \neq sB$$

consistent Anomaly = solution to consistency condition

consistent Anomaly = non-trivial element of the BRST cohomology on the space of local functionals

# Covariant Anomaly

Consistent current is not gauge invariant

$$[\delta_\lambda, \frac{\delta}{\delta A_\mu}] = 0 \quad \delta_\lambda J^\mu = \frac{\delta \mathcal{A}_\lambda}{\delta A_\mu} \neq 0$$

Define “covariant” current via

$$\delta_\lambda J^\mu = 0 \quad \delta_\lambda J^{\mu,a} = i f^{abc} \lambda^b J^{\mu,c} \quad (\text{non-abelian})$$

Solution: Bardeen-Zumino polynomial

$$J_{\text{cov}}^{\mu,a} = J_{\text{cons}}^{\mu,a} + Y^{\mu,a}[A]$$

chiral fermion:  $J_{L,R,\text{cov}}^\mu = J_{R,L,\text{cons}}^{\mu,a} \pm \frac{1}{24\pi^2} \epsilon^{\mu\nu\rho\lambda} A_\nu F_{\rho\lambda}$

BZ polynomial is not variation of local functional

$$Y^{\mu,a}[A_\mu] \neq \frac{\delta X}{\delta A_\mu^a}$$

# General Chiral Anomaly

$$(\nabla_{\mu} J^{\mu})_A = \frac{d_{ABC}}{32\pi^2} \epsilon^{\mu\nu\rho\lambda} F_{\mu\nu}^B F_{\rho\lambda}^C$$

$$d_{ABC} = \text{str} (T_A T_B T_C)_L - \text{str} (T_A T_B T_C)_R$$

- Covariant Anomaly or totally symmetric consistent anomaly
- Consistent anomalies can be shifted between symmetries via Bardeen counterterms but not totally cancelled
- Covariant and Consistent currents are related by Bardeen-Zumino polynomials (Chern-Sions currents)

# Gravitational chiral Anomaly

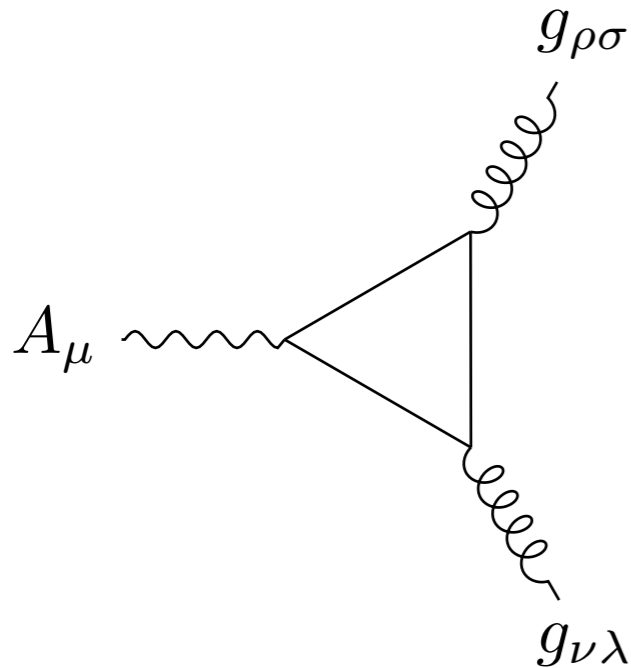

$$(D_\mu J_A^\mu) = \frac{b_A}{768\pi^2} \epsilon^{\mu\nu\rho\lambda} \mathcal{R}^\alpha{}_{\beta\mu\nu} \mathcal{R}^\beta{}_{\alpha\rho\lambda}$$

$$b_A = \text{tr}(T_A)_L - \text{tr}(T_A)_R = \sum_r q_A^r - \sum_l q_A^l$$

- No purely gravitational anomaly in 4D
- Mixed between (chiral) U(1) and diffeomorphisms
- Physical application: decay of  $\pi^0$  into 2 gravitons
- Unmeasurable in HEP
- Contribution to transport (QGP, ? WSMs ?)



# Anomalies and Landau levels

Chiral fermions in magnetic field:

Landau Levels:  $n > 0$

$$E_n = \pm \sqrt{p_z^2 + 2eB(n + 1/2)} + seB$$

Lowest Landau Level :  $n=0$

$$E_0 = \pm p_z$$

Sign is determined by **chirality**

Degeneracy of LL:  $\frac{eB}{2\pi}$

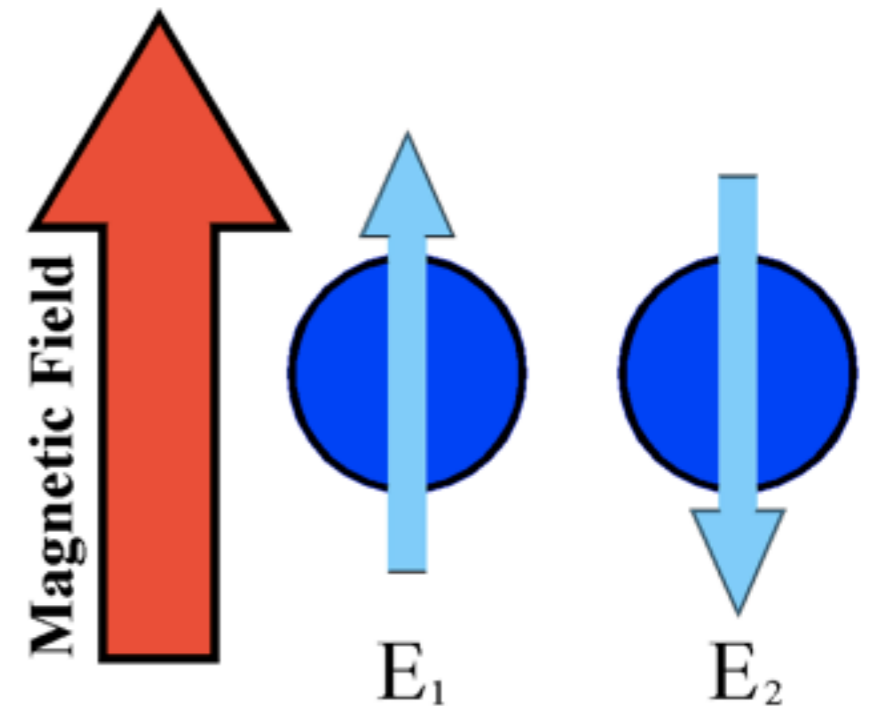

# Anomalies:

In additional electric field fermions feel Lorentz force

$$\frac{d}{dt}p_z = eE_z$$

The density of states changes as

$$dn = \frac{dp}{2\pi} \frac{eB}{2\pi}$$

[Nielsen, Ninomiya], [Gribov]

**Anomaly**

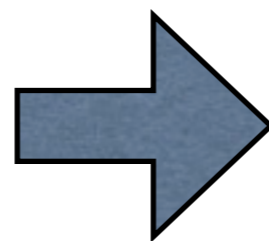

$$\frac{dn}{dt} = \frac{e^2 \vec{B} \vec{E}}{4\pi^2}$$

# Anomalies:

## Spectral Flow Chiral Anomaly

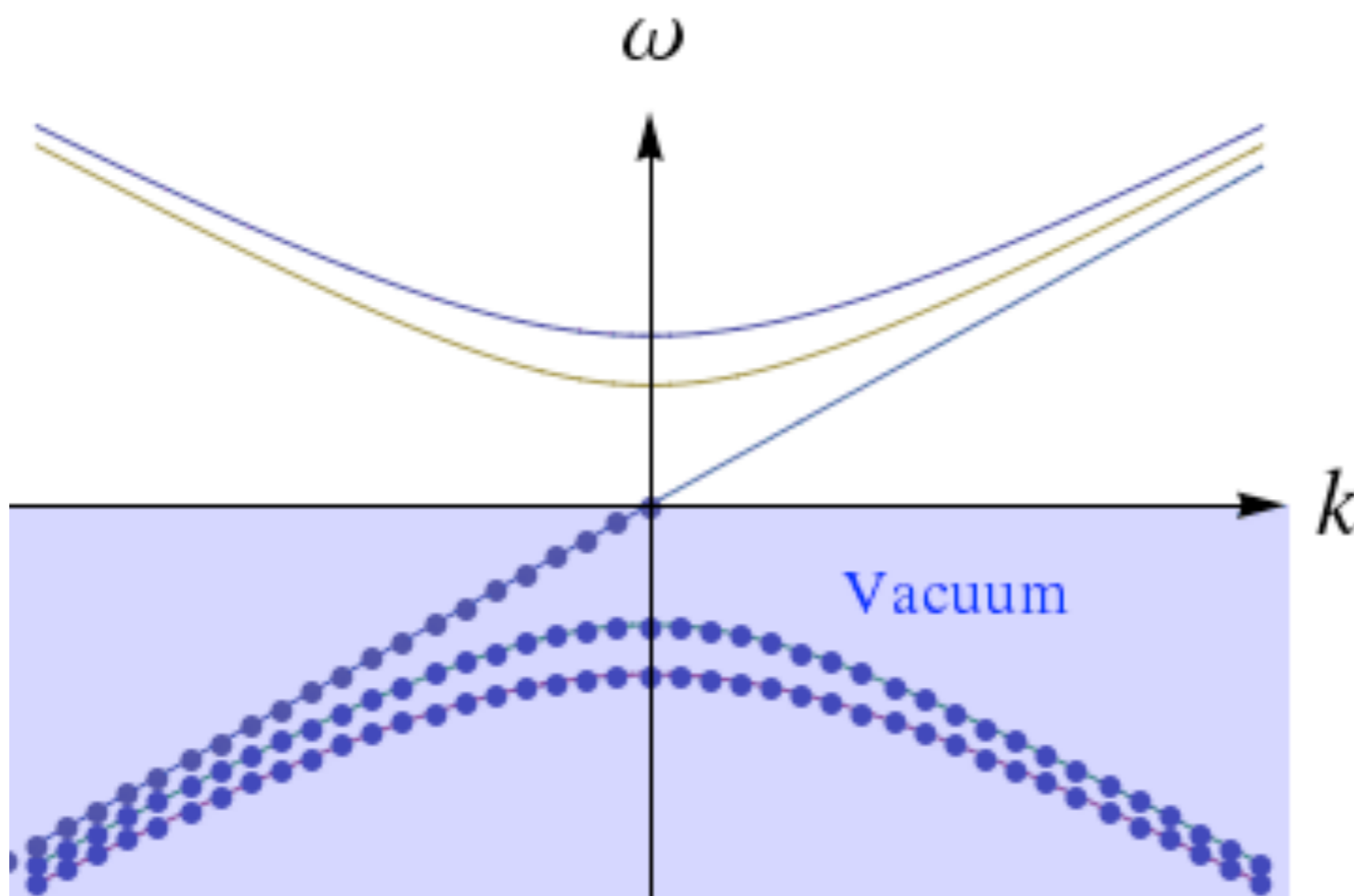

**Anomaly** →

In additional electric field fermions feel Lorentz force

$$\frac{d}{dt}p_z = eE_z$$

The density of states changes as

$$dn = \frac{dp}{2\pi} \frac{eB}{2\pi}$$

[Nielsen, Ninomiya], [Gribov]

$$\frac{dn}{dt} = \frac{e^2 \vec{B} \vec{E}}{4\pi^2}$$

# Anomalies:

$$n = n_R + n_L$$

$$n_5 = n_R - n_L$$

$$\frac{d(n_L + n_R)}{dt} = 0$$

$$\frac{d(n_L - n_R)}{dt} = \frac{1}{2\pi^2} (\vec{E} \vec{B})$$

# Anomalies:

$$n = n_R + n_L$$

$$n_5 = n_R - n_L$$

$$\frac{d(n_L + n_R)}{dt} = 0$$

$$\frac{d(n_L - n_R)}{dt} = \frac{1}{2\pi^2} (\vec{E} \vec{B})$$

## Spectral Flow Axial Anomaly

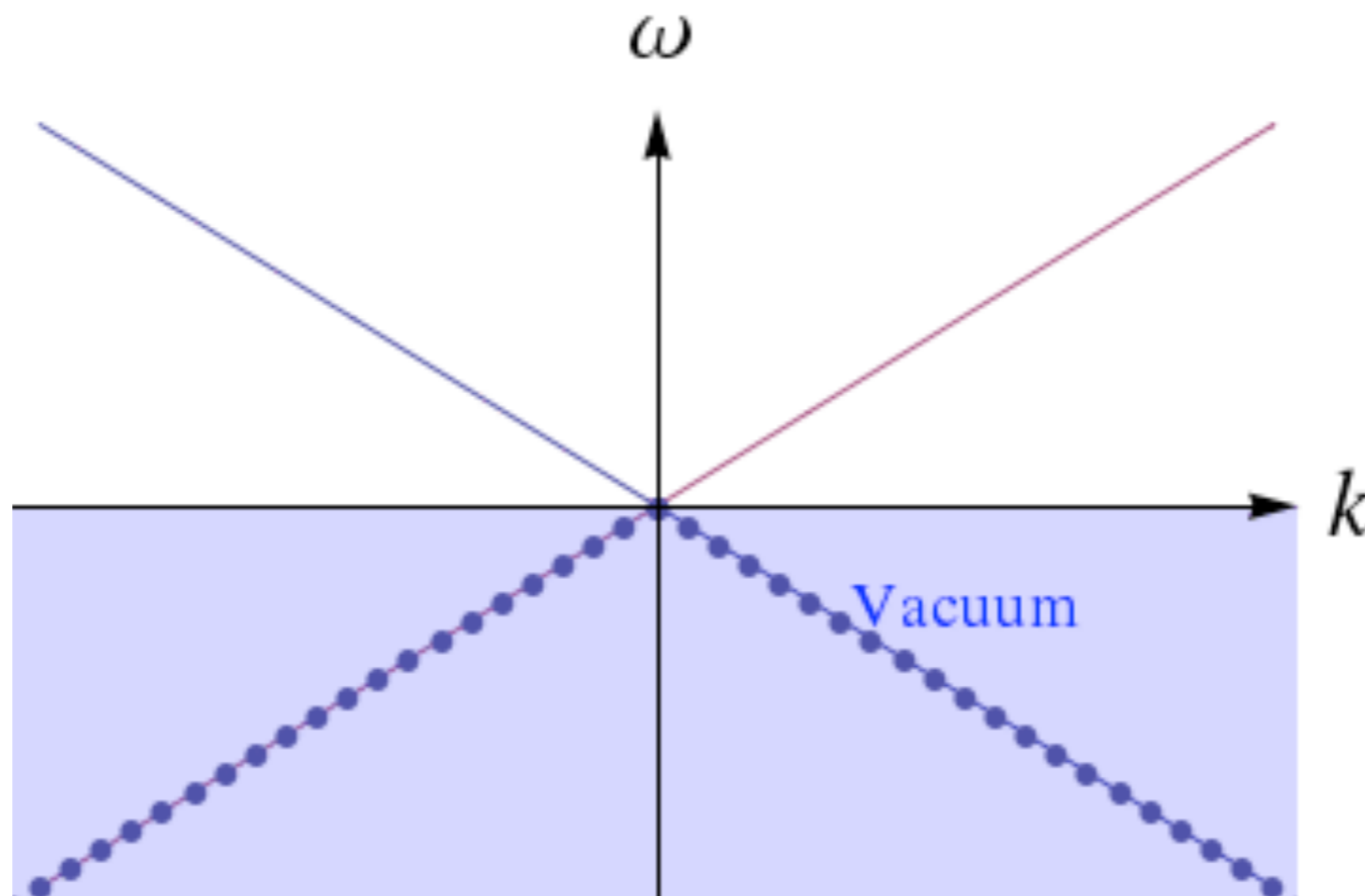

# Anomalies:

sum of left and right ?

$$\frac{dn_{L,R}}{dt} = \pm \frac{1}{4\pi^2} \vec{E} \vec{B} = \pm \frac{1}{32\pi^2} \epsilon^{\mu\nu\rho\lambda} F_{\mu\nu} F_{\rho\lambda}$$

Assume independent gauge fields for left and right handed fermions

$$\frac{dn_L + n_R}{dt} = \pm \frac{1}{2\pi^2} (\vec{E}_5 \vec{B} + \vec{E} \vec{B}_5)$$

$$\frac{dn_L - n_R}{dt} = \pm \frac{1}{2\pi^2} (\vec{E} \vec{B} + \vec{E}_5 \vec{B}_5)$$

covariant anomaly

$$\partial_\mu \partial_\nu F^{\mu\nu} = \partial_\mu J^\mu = 0 \quad !!!$$

# Anomalies: Covariant vs. Consistent:

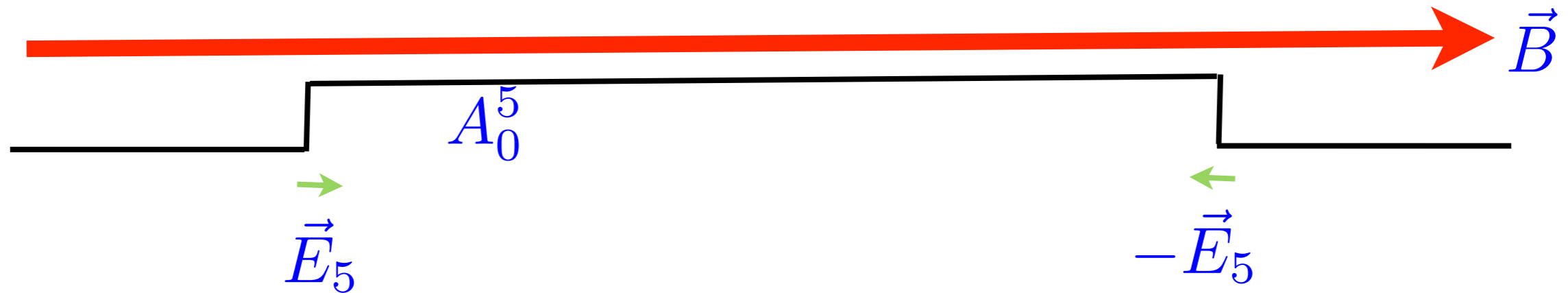

$$\vec{J}_{C.S} = -\frac{1}{2\pi^2} A_0^5 \vec{B}$$

Chern-Simons current via boundary conditions at cutoff

# Anomalies: Covariant vs. Consistent:

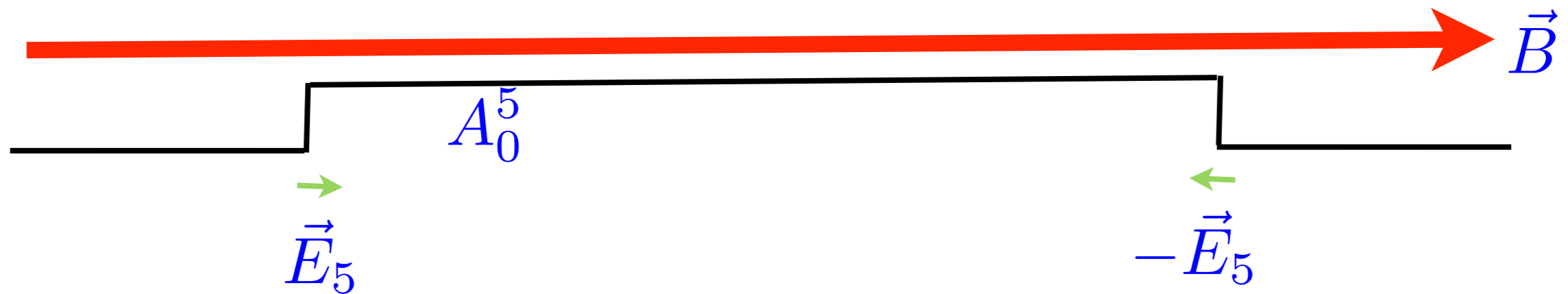

Spectral Flow Consistent Anomaly,  $x=L$

Spectral Flow Consistent Anomaly,  $x=-L$

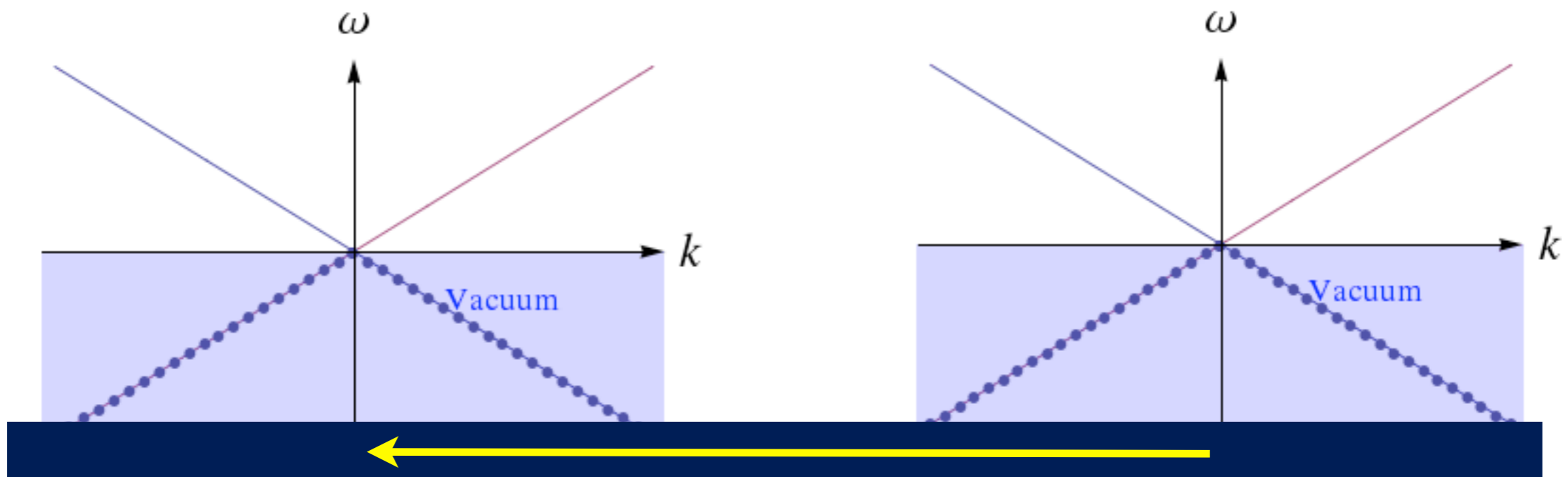

$$\vec{J}_{C.S} = -\frac{1}{2\pi^2} A_0^5 \vec{B}$$

Chern-Simons current via boundary conditions at cutoff



# Anomalies: Covariant vs. Consistent:

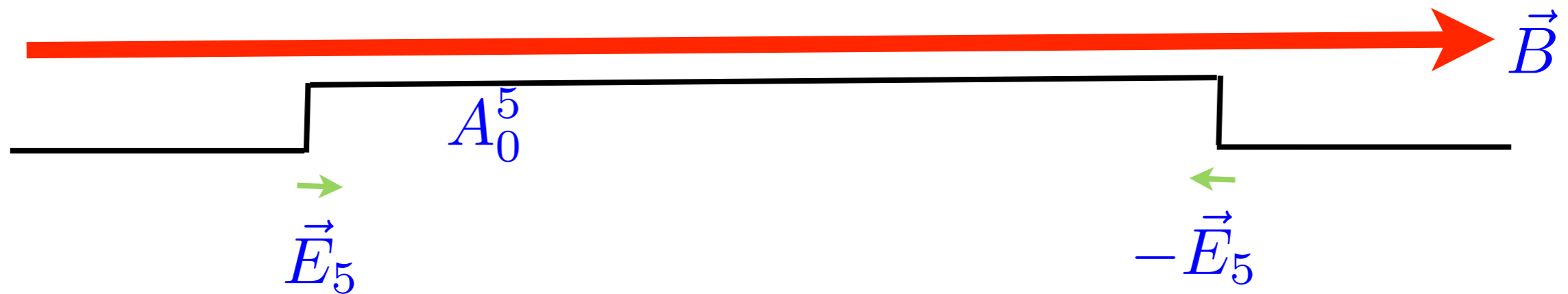

Spectral Flow Consistent Anomaly,  $x=L$

Spectral Flow Consistent Anomaly,  $x=-L$

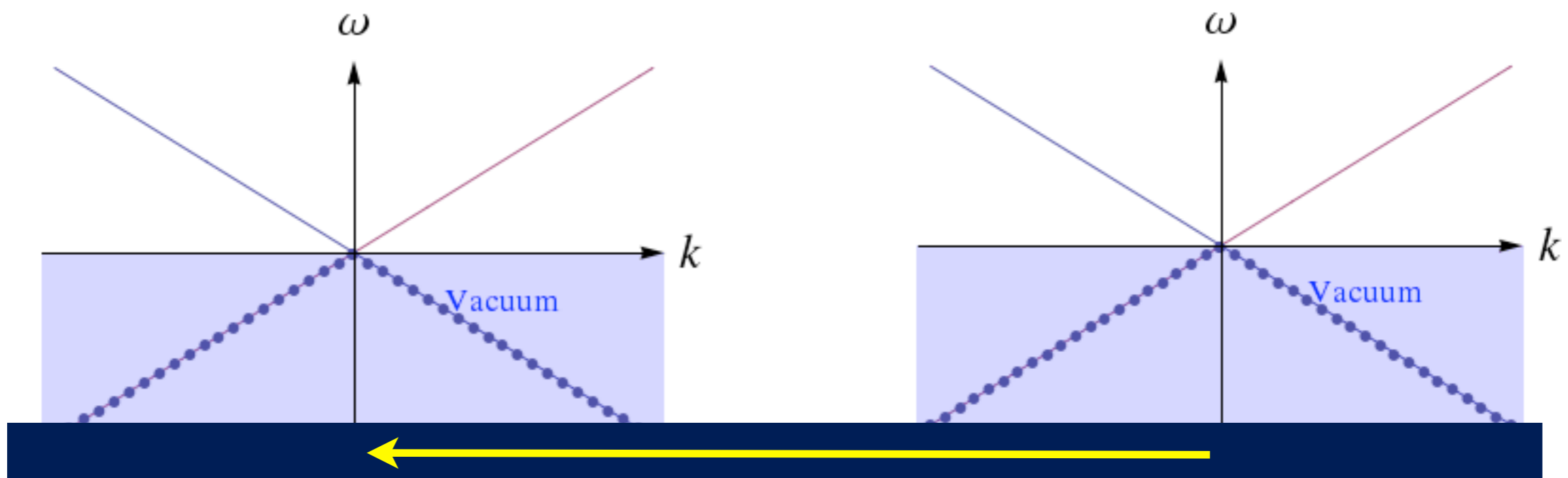

$$\vec{J}_{C.S} = -\frac{1}{2\pi^2} A_0^5 \vec{B}$$

Chern-Simons current via boundary conditions at cutoff

# Anomalies: Covariant vs. Consistent:

$$J_{\text{cons}}^{\mu} = J_{\text{cov}}^{\mu} - \frac{1}{4\pi^2} \epsilon^{\mu\nu\rho\lambda} A_{\nu}^5 F_{\rho\lambda}$$

$$\vec{J}_{CS} = -\frac{A_0^5}{2\pi^2} \vec{B}$$

$$\vec{J}_{CS} = \frac{1}{2\pi^2} \vec{A}_5 \times \vec{E}$$

$$J_{CS}^0 = \frac{1}{2\pi^2} \vec{A}_5 \cdot \vec{B}$$

- Covariant current is covariant under all “gauge” trafos (even anomalous ones)
- Consistent current is solution to Wess-Zumino consistency condition
- Consistent vector-current can be made exactly conserved: electric current
- Both are related by gauge invariant Chern-Simons current
- Consistent current automatic in gauge invariant regularization (DimReg, lattice)
- $\exists$  local counterterms to define consistent current (Bardeen)
- CS current = vacuum current (akin to quantum hall effect)
- Although this looks like the CME it is not (at least not all)

# Landau Levels and Transport

Landau levels of chiral fermion in magnetic field

$$\text{HLLs:} \quad E_n = \sqrt{p_z^2 + nB}$$

$$\text{LLL:} \quad E_0 = \pm p_z$$

Current = charge.velocity

$$\text{HLLs:} \quad \int_{-\infty}^{\infty} \frac{dp_z}{2\pi} \frac{\partial E_n}{\partial p_z} \left( \frac{1}{e^{\frac{E_n - \mu}{T}} + 1} - \frac{1}{e^{\frac{E_n + \mu}{T}} + 1} \right) = 0$$

$$\text{LLL:} \quad \int_0^{\infty} \frac{dp_z}{2\pi} (\pm 1) \left( \frac{1}{e^{\frac{E_0 - \mu}{T}} + 1} - \frac{1}{e^{\frac{E_0 + \mu}{T}} + 1} \right) = \frac{\mu}{2\pi}$$

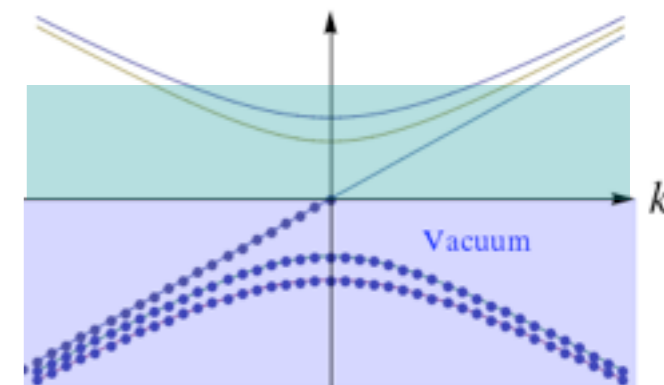

Taking degeneracy of LLL into account :

**Chiral Magnetic Effect (CME)**

$$\vec{J}_{L,R} = \pm \frac{\mu}{4\pi^2} \vec{B}$$

# Landau Levels and Transport

Energy transport =  $\mathbf{E} \cdot \mathbf{v} = \mathbf{p} =$  Momentum density

$$\begin{aligned}\vec{P}_{L,R} = \vec{J}_{\epsilon,L,R} &= \pm \int_0^\infty \frac{dp_z}{2\pi} \left( \frac{p}{e^{\frac{p-\mu}{T}} + 1} + \frac{p}{e^{\frac{p+\mu}{T}} + 1} \right) \\ &= \pm \frac{T^2}{2\pi} \left[ Li_2(-e^{\mu/T}) + Li_2(-e^{-\mu/T}) \right]\end{aligned}$$

Jonquiere inversion relations: Bernoulli polynomials

**Chiral Magnetic Effect (CME)** in energy current

$$\vec{J}_{\epsilon,L,R} = \pm \left( \frac{\mu_{L,R}^2}{8\pi^2} + \frac{T^2}{24} \right) \vec{B}$$

# Chiral Magnetic Effect :

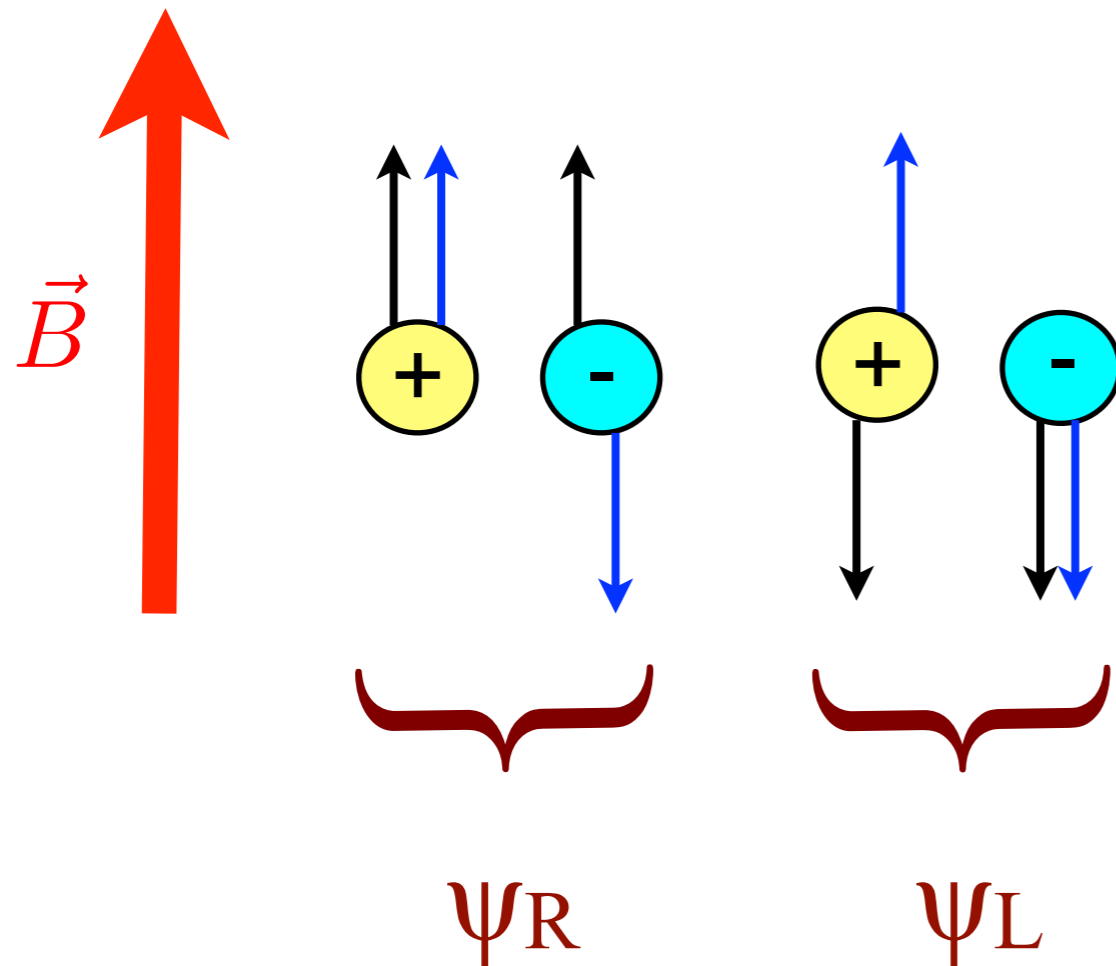

$$\vec{J}_{\text{cov}} = \frac{\mu_5}{2\pi^2} \vec{B}$$

$$\mu_5 = \frac{1}{2} (\mu_R - \mu_L)$$

**Axial chemical potential: counts occupied states above vacuum!**

[Vilenkin], [Shaposhnikov, Giovannini],  
 [Alekseev, Chaianov, Fröhlich] [Newman]  
 [Kharzeev, Fukushima, Warringa],[Son,Surowka]

# Rotation

Heuristics: similarity Coriolis force and Lorentz force

$$\vec{F} = 2m\vec{v} \times \vec{\Omega} \quad \vec{F} = q\vec{v} \times \vec{B}$$

Charge is replaced by energy (E=m)  $q\vec{B} \rightarrow E2\vec{\Omega}$

## Chiral Vortical Effect (CVE)

$$\vec{J}_{\epsilon,L,R} = \pm \int_0^\infty \frac{dp_z}{2\pi} \left( \frac{p}{e^{\frac{p-\mu}{T}} + 1} + \frac{p}{e^{\frac{p+\mu}{T}} + 1} \right) \frac{\vec{\Omega}}{\pi} = \left( \frac{\mu_{L,R}^2}{4\pi^2} + \frac{T^2}{12} \right) \vec{\Omega}$$

$$\vec{J}_{\epsilon,L,R} = \pm \int_0^\infty \frac{dp_z}{2\pi} \left( \frac{p}{e^{\frac{p-\mu}{T}} + 1} + \frac{p}{e^{\frac{p+\mu}{T}} + 1} \right) \frac{\vec{\Omega}}{\pi} = \left( \frac{\mu_{L,R}^3}{6\pi^2} + \frac{\mu_{L,R}T^2}{6} \right) \vec{\Omega}$$

# Relation to anomalies

Assume  $N_A$  different  $U(1)$  symmetries and  $N_f$  chiral fermion species with charges  $q_A^f$

$$B \rightarrow q_A^f B_A \quad , \quad \mu \rightarrow q_A^f \mu_A \quad , \quad J \rightarrow J^f q_A^f = J_A$$

$$\vec{J}_A = d_{ABC} \frac{\mu_B}{4\pi^2} \vec{B}_C + \left( d_{ABC} \frac{\mu_B \mu_C}{4\pi^2} + b_A \frac{T^2}{12} \right) \vec{\Omega}$$

$$\vec{J}_\epsilon = \left( d_{ABC} \frac{\mu_B \mu_C}{8\pi^2} + b_A \frac{T^2}{24} \right) \vec{B}_A + \left( d_{ABC} \frac{\mu_A \mu_B \mu_C}{6\pi^2} + b_A \frac{\mu_A T^2}{6} \right) \vec{\Omega}$$

$$d_{ABC} = \sum_r q_A^r q_B^r q_C^r - \sum_l q_A^l q_B^l q_C^l$$

$$b_A = \sum_r q_A^r - \sum_l q_A^l$$

Strong hint that currents are determined by anomalies

# Examples

A-V theory:  $d_{5VV} = d_{V5V} = d_{VV5} = 2$

Chiral Magnetic Effect (CME):  $\vec{J} = \left( \frac{\mu_5}{2\pi^2} - \frac{A_0^5}{2\pi^2} \right) \vec{B}$

Chiral Separation Effect (CSE):  $\vec{J}_5 = \frac{\mu}{2\pi^2} \vec{B}$

Axial Magnetic Effect (AME):  $\vec{J} = \frac{\mu}{2\pi^2} \vec{B}_5$

We will discuss applications of all three !



# Summary:

- Triangle finite but regularization dependent (“finite but undetermined”)
- Physical condition fixes consistent anomaly
- Covariant vs. Consistent current, Chern-Simons current
- Anomalies (covariant) and Landau Levels (spectral flow)
- Chiral Magnetic and Chiral Vortical effects from Lowest Landau Level
- Relation to Anomalies indicated by anomaly coefficients

# Outlook:

- Relativistic Hydrodynamics
- CME and CVE from from 2nd law
- Application: Quark Gluon Plasma
- Application: Negative Magneto Resistivity (NMR)